



**EBARA**

CS2510EK

# VERTICAL MULTISTAGE CANNED PUMP

Low NPSH Application For Process, Condensate and General Industrial Services

## Models VPCS/VPCH

API 610

API 682

\*「Model 〇〇〇」 in this catalogue is our model code.

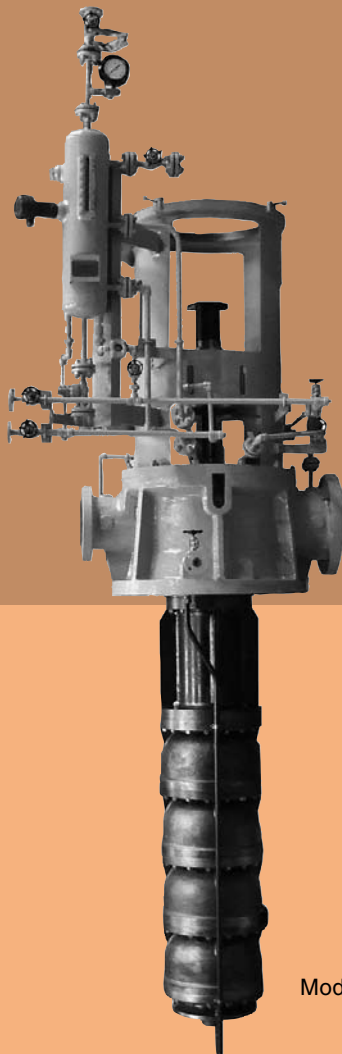

Model VPCS

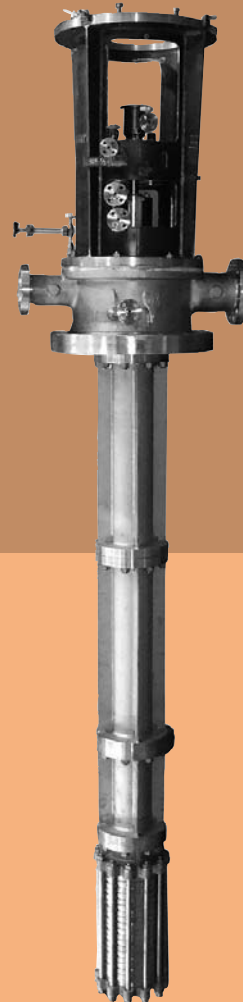

Model VPCH

# VERTICAL MULTISTAGE CANNED PUMP

Low NPSH Application For Process, Condensate and General Industrial Services

## Models VPCS/VPCH

**API 610** **API 682**

EBARA MODEL VPCS and VPCH VERTICAL MULTI-STAGE CANNED PUMPS have been widely used in petroleum refineries, for the petrochemical industry, condensate and general industrial services. Many improvements have been

recently made on this pump to enhance its performance. Model VPCS is classified as a low and medium pressure type and model VPCH as a high pressure type pump. Unique design of this high performance pump provides for

superior and extended low cost operation. Our modern tape controlled machines in conjunction with advanced quality control procedures insure that these pumps meet our high manufacturing standards.

### Applications

- Petroleum Refineries
- Petrochemical Industries
- Condensate and General Industrial Services

### Ratings

Capacities	To 5500m <sup>3</sup> /h (24200 USGPM)
Heads	To 1600 m (5250 ft)
Max. working pressure	To gauge pressure 14.7MPa (2130PSI)
Rotation	Clockwise viewed from inboard side
Impeller type	Enclosed
Temperatures	-105°C to 340°C (-157°F to 644°F)
Flanges	ANSI class 300 as standard, other standard also available
Nozzles	Side-Side
Stuffing box	Suitable for mechanical seal & conventional packing

### Features

- Low NPSH
- High reliability
- Minimum installation space
- Minimum labor required for installation and piping
- Full compliance with API 610 and API 682 specifications.

### Selection of Types

Total Pressure of Pump	14.7 {150}	Model VPCH High Pressure Type (Inner casing working pressure up to gauge pressure 8.83MPa)
	4.9 {50}	Model VPCS Med. Pressure Type (Inner casing working pressure up to gauge pressure 3.24MPa)

gauge pressure MPa

### Designation

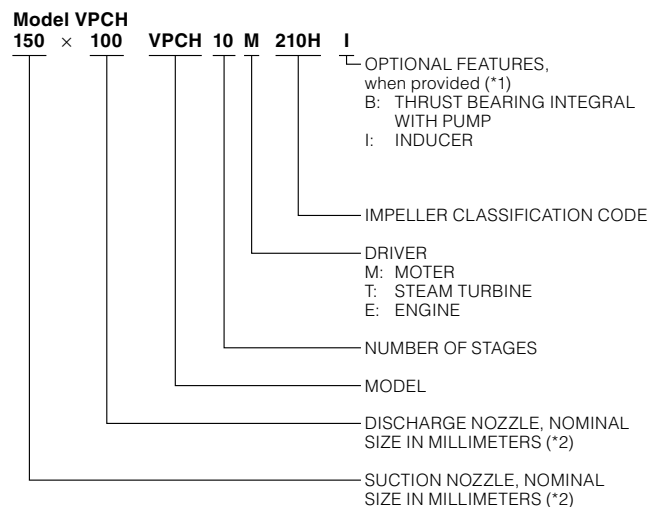
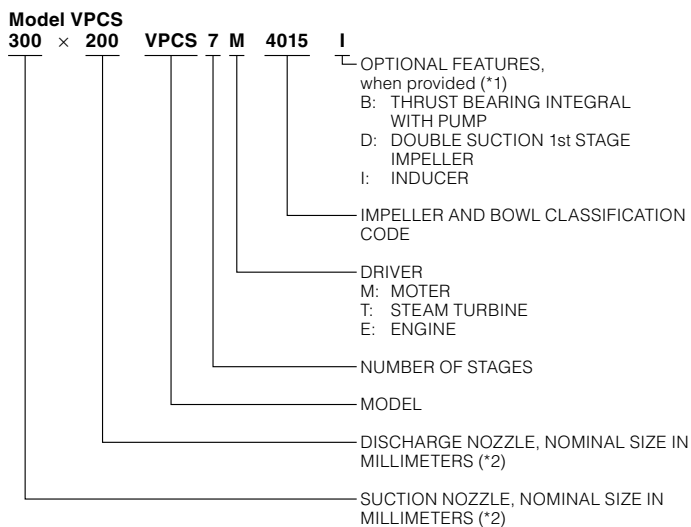

NOTES: (\*1) When two features are involved, the codes are in alphabetical order.

(\*2) For use in customer's vessels or pits, VPCS pumps can be furnished without a suction can. In this case, only discharge nozzle size is indicated, i.e. 200 VPCS7M 4015 means a pump without a suction can.

Model VPCS

2000 SERIES

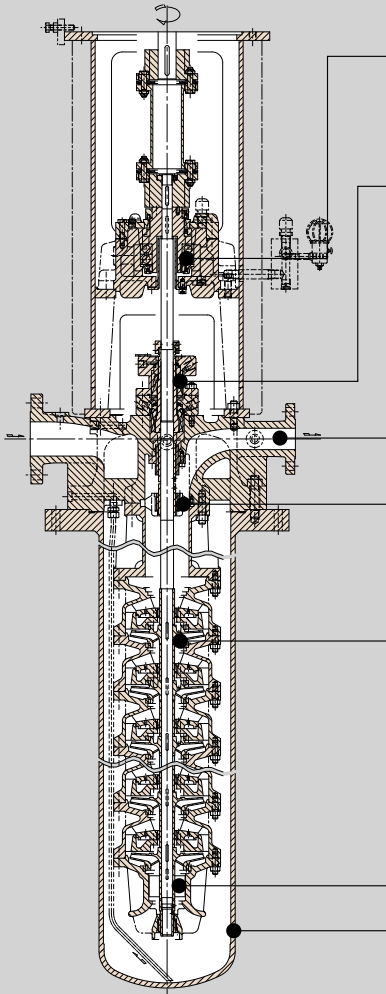

**Thrust Bearing:** The thrust bearings consist of back-to-back angular contact bearings. Standard lubrication system is flood.

**Mechanical Seal:** The balanced cartridge type mechanical seal is flushed and vented to provide reliable service over a wide range of pressures. Seal replacement is easily accomplished.

**Discharge Head:** On smaller sized pumps casings are usually integrally cast with the upper pump body, while larger pump bores use casing of welded construction.

**Intermediate Bearings:** Bearing materials, composition of which is determined according to the liquid handled, is retained in integral cast casings. Number of bearings is determined by critical pump speed and shaft length.

**Impeller:** Machined finishing of closed vane impellers improves hydraulic efficiency. Suction is further improved by incorporation of uniquely designed first stage impeller. Double suction first stage impellers are available for larger pumps.

**Inducer:** Incorporation of an inducer on the inlet side of the first stage impeller improves suction. Inducer may reduce barrel length for restrictive installations.

**Suction Can (Barrel):** The highly reliable welded barrel can easily meet local standards governing treatment of high pressure gasses.

4000 AND 6000 SERIES

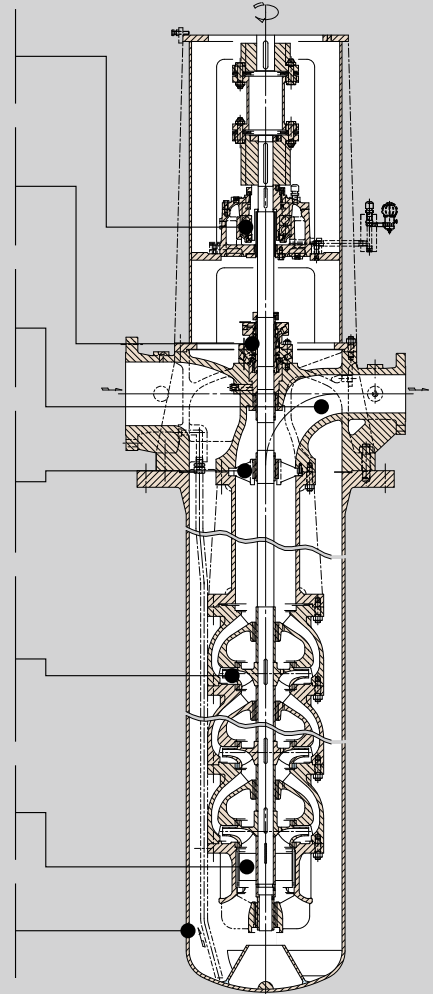

Metallurgy

Name of Parts	Materials JIS/ASTM-AISI				
	C. Steel	C. Steel	12% Cr. Steel	304 S. Steel	316 S.Steel
Discharge Head	SCPH2/A216WCB	SCPL1/A352LCB	SCS1/A743CA15	SCS13A/A743CF8	SCS14A/A743CF8M
Inner Casing	SCPH2/A216WCB	SCPL1/A352LCB	SCS1/A743CA15	SCS13A/A743CF8	SCS14A/A743CF8M
Barrel	STPT410, SM400B, SFVC2A/A106, A131, A266	STPL380, SLA235B, SFL2/A333, A662, A350	STPT410, SM400B, SFVC2A/A106, A131, A266	SU304TP, SUS304/A312 TP304, A240 Type 304	SUS316TP, SUS316/A312 TP316, A240 Type316
Impeller	SCS1/A743CA15	SCS13A/A743 CF8	SUS1/A743 CA15	SCS13A/A743CF8	SCS14A/A743CF8M
Shaft	SUS403/A276	SNC815/A322	SUS403/A276	SUS304/A276	SUS316/A276
Case Wear Ring	FCD400/A536	FCD400/A536	SUS420J1/A276	SUS304/A276	SUS316/A276
Impeller Wear Ring	SUS420J2/A276	SUS304/A276	SUS420J2/A276	SUS304/A276	SUS316/A276
Sleeve for Mechanical Seal	SUS316/A276	SUS316/A276	SUS316/A276	SUS304/A276	SUS316/A276

Notes: Other materials supplied on request.

- Standard Materials
- Optional Materials

Model VPCH

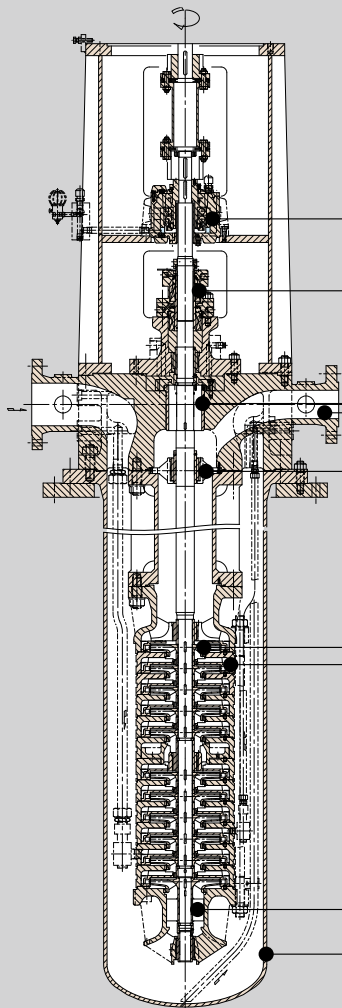

**Thrust Bearing:** The thrust bearings consist of back-to-back angular contact bearings. Standard lubrication system is flood.

**Mechanical Seal:** A balanced cartridge type mechanical seal is utilized. It is flushed and vented to provide reliable service over a wide range of pressures with ease of replacement.

**Balancing Piston:** To balance shaft thrust and reduce thrust imposed on thrust-bearing, a balancing piston is incorporated.

**Discharge Head:** The high pressure types utilize casting construction. The casings possess adequate strength against inner pressure and sufficient rigidity against outer stress.

**Intermediate Bearings:** Bearing materials, are selected according to the liquid to be pumped. In addition, the number of bearings is determined in relation of critical speed and shaft length.

**Impeller:** The impeller at each stage is enclosed type with all surfaces machine finished so that the highest hydraulic efficiency may be obtained. In addition, the first stage impeller incorporates a unique design for enhancing the suction performance, and minimizing the NPSH requirement.

**Intermediate Casing:** Hydraulically efficient casing design, based on many years experience, minimizes pump friction losses.

**Inducer:** Incorporation of an inducer on the inlet side of the first stage impeller improves suction. Inducer may reduce barrel length for restrictive installations.

**Suction Can (Barrel):** The welded barrel ensures high reliability.

Metallurgy

Name of Parts	Materials JIS/ASTM-AISI			
	C. Steel	C. Steel	12% Cr. Steel	316 S. Steel
Discharge Head	SCPH2/A216WCB	SCPL1/A352LCB	SCS1/A743CA15	SCS14A/A743CF8M
Inner Casing	S35C/A105	SFL2/A350 Gr.LF2	SUS420J1/AISI 420	SCS316/A182 F316
Barrel	SB410, SFVC2A, SM400B/A285, A105, A131	STPL380, SLA235B, SFL2/A333, A662 Gr.A, A350	SB410, SFVC2A, SM400B/A285, A105, A131	SUS316TP,SUS316/A312 TP316, A240 Type316
Impeller	SCS1/A743 CA15	SCS13A/A743 CF8	SUS1/A743 CA15	SCS14A/A743 CF8M
Shaft	SUS403/A276	SNC815/A322	SUS403/A276	SUS316/A276
Case Wear Ring	SUS402J1/A276	FCD400/A536	SUS420J1/A276	SUS316/A276
Impeller Wear Ring	SUS420J2/A276	SUS304/A276	SUS420J2/A276	SUS316/A276
Sleeve for Mechanical Seal	SUS316/A276	SUS316/A276	SUS316/A276	SUS316/A276

Notes: Other materials supplied on request.

- Standard Materials
- Optional Materials

Model VPCS

50 Hz

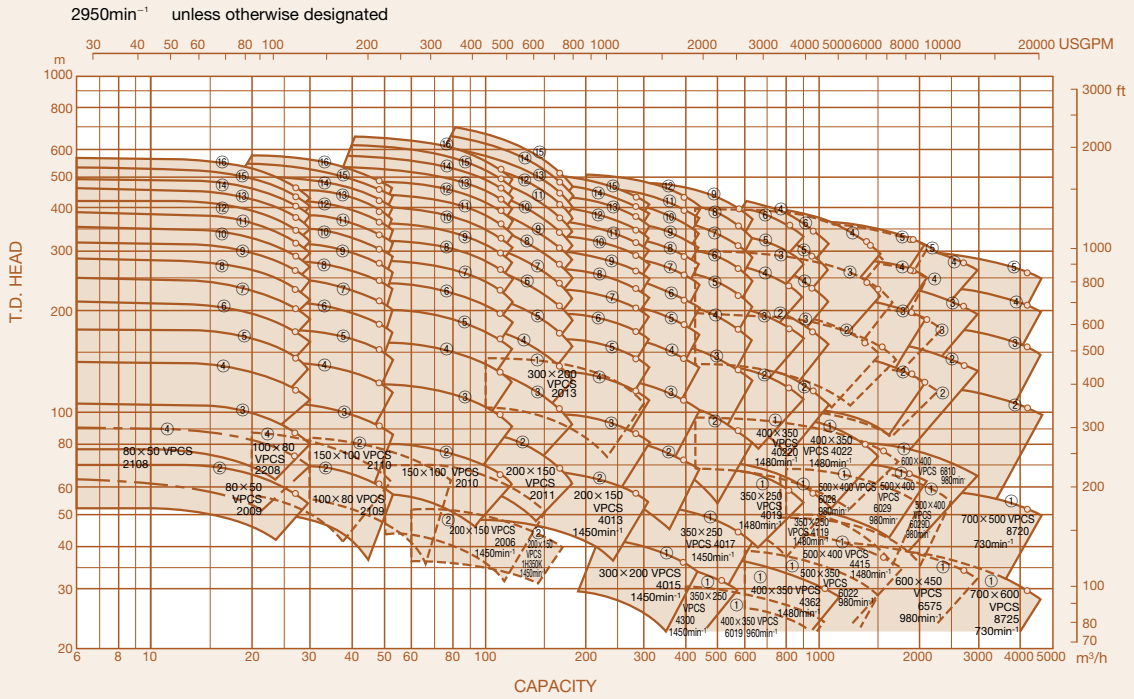

Model VPCH

50 Hz

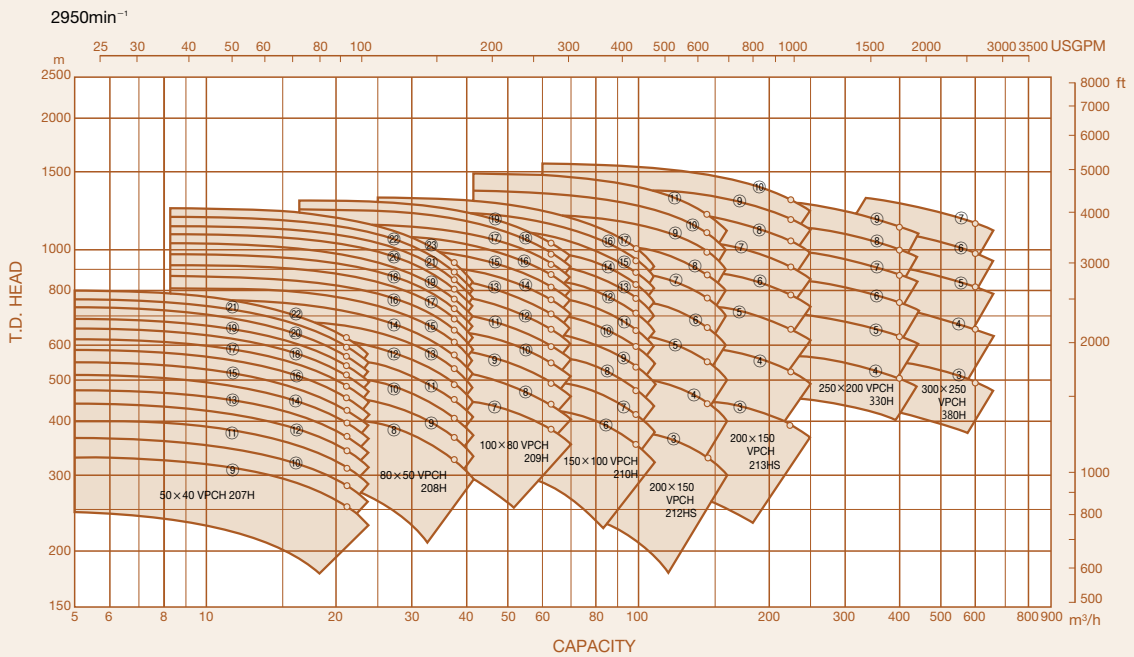

These selection charts are prepared for preliminary selection. Refer to individual performance curves for final selection.  
 ○ denotes B.E.P. of the performance with an impeller of maximum diameter.  
 The number of stages is indicated in the circle.

Model VPCS

60 Hz

3550 min<sup>-1</sup> unless otherwise designated

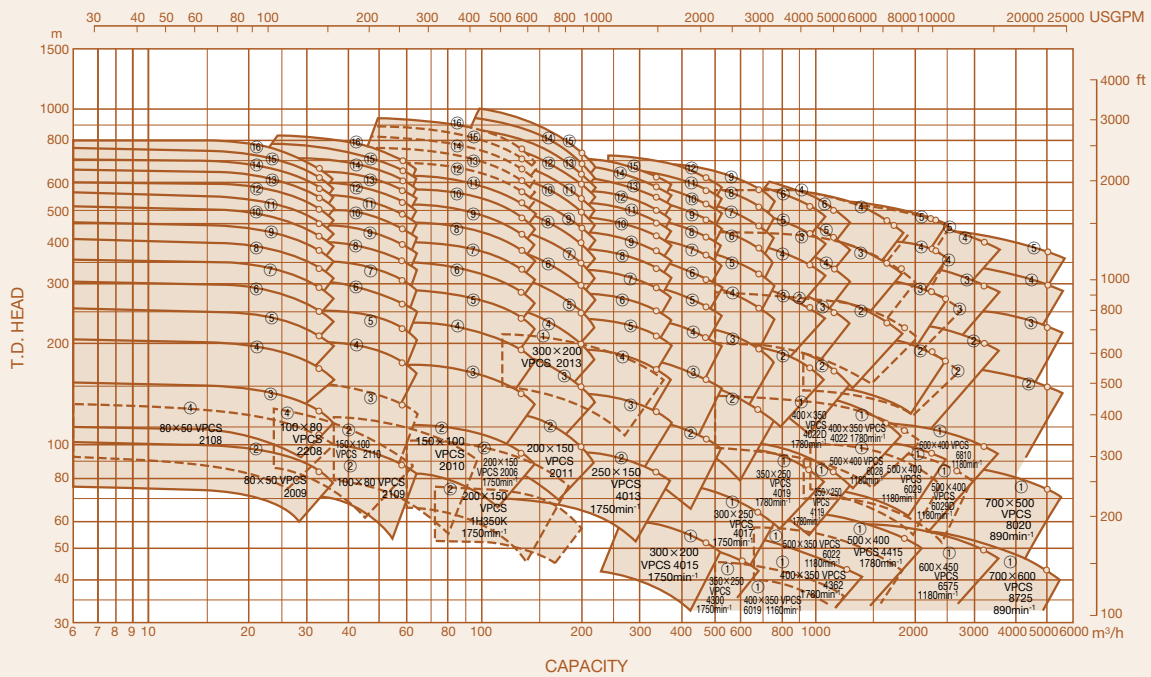

Model VPCH

60 Hz

3550 min<sup>-1</sup>

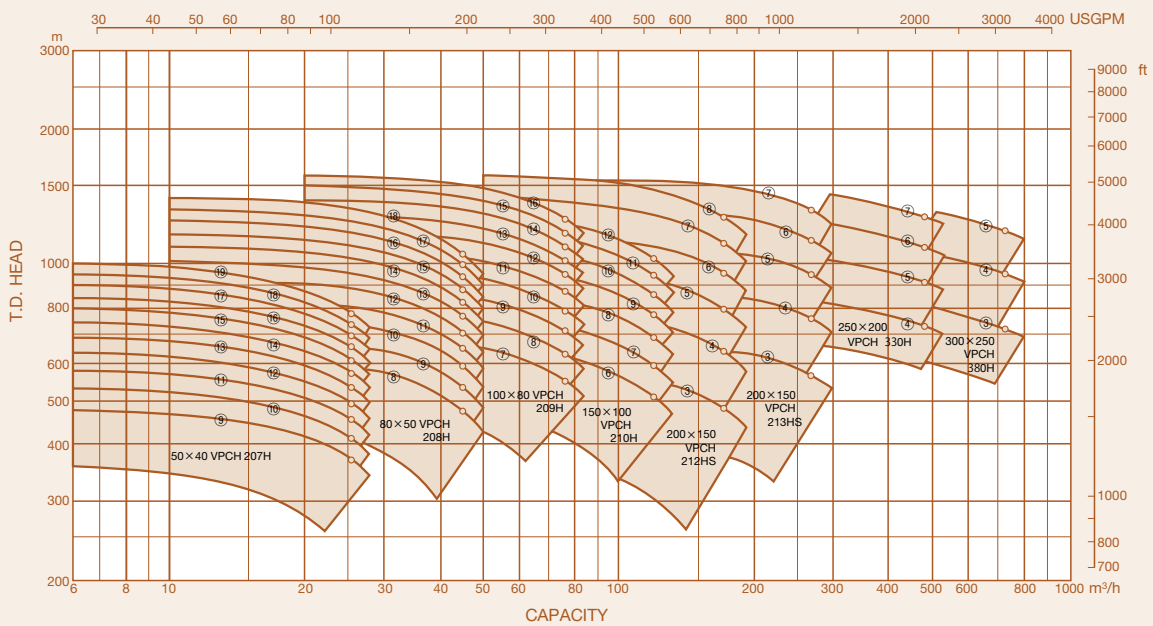

These selection charts are prepared for preliminary selection. Refer to individual performance curves for final selection.  
 ○ denotes B.E.P. of the performance with an impeller of maximum diameter.  
 The number of stages is indicated in the circle.



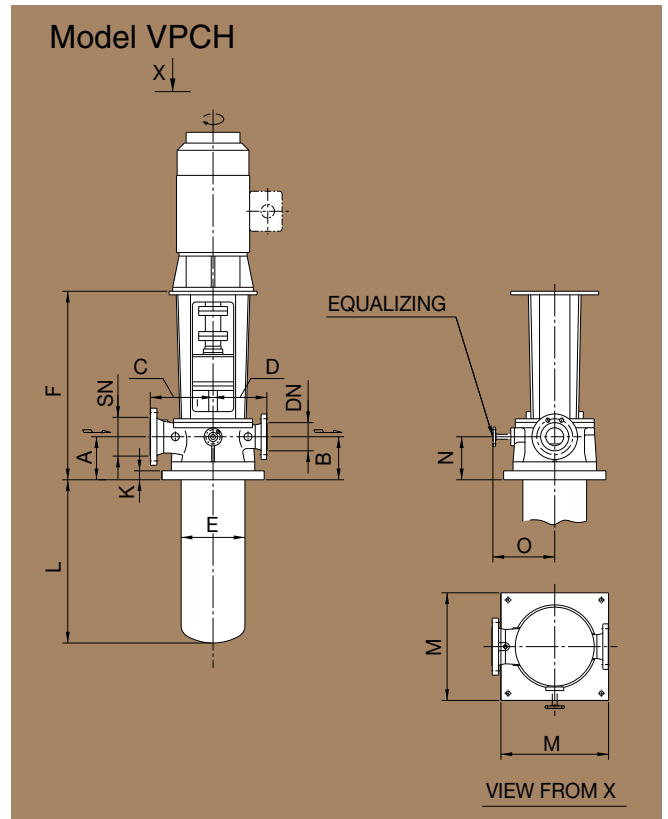
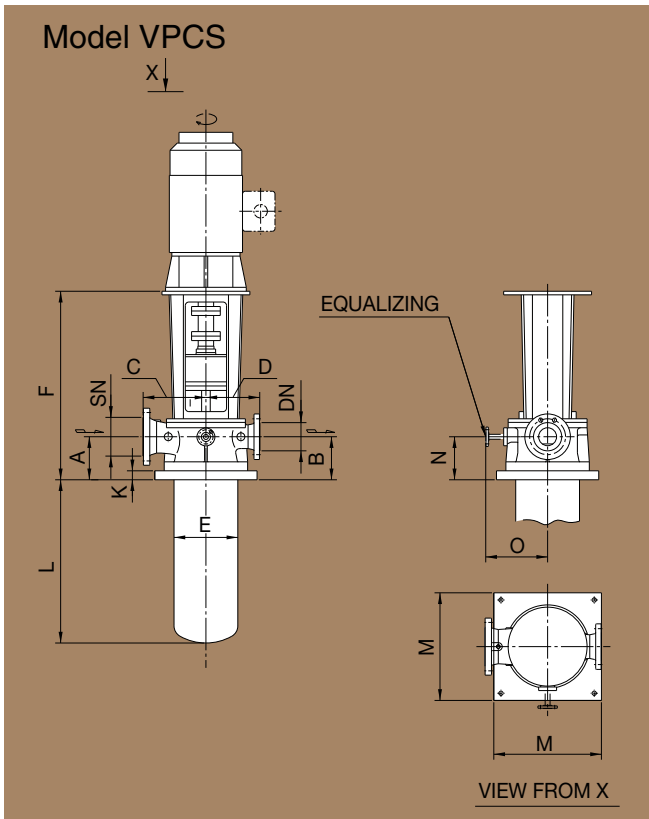

Model VPCS

Dimensions: mm

PUMP SIZE	SN	DN	A	B	C	D	E	F	K	M	N	O	
80x50	2108, 2009	80	50	213.5	213.5	320	300	318.5	1,200	50	600	210.5	380
100x80	2208, 2109	100	80	233	233	320	300	318.5	1,250	50	600	248	380
150x100	2010, 2110	150	100	243.5	243.5	350	300	355.6	1,350	50	600	271.5	400
200x150	2011	200	150	304.5	304.5	400	400	406.4	1,500	50	750	352.5	400
200x150	2006	200	150	435	435	600	600	744	1,850	65	1,300	455	700
200x150	1H350K	200	150	365	365	550	550	638	1,700	60	1,100	468	550
250x150	4013	250	150	365	365	550	550	638	1,950	65	1,100	422	600
300x200	2013	300	200	440	440	650	650	744	1,800	70	1,300	500	700
300x200	4015	300	200	445	445	650	650	744	2,100	75	1,300	505	700
350x250	4017	350	250	483	483	700	700	850	2,200	75	1,300	548	750
350x250	4300	350	250	460	460	650	600	674	2,200	70	1,300	530	750
350x250	4019, 4119	350	250	508	508	780	780	956	2,200	80	1,450	608	850
400x350	4362	400	350	463	463	800	800	874	2,200	70	1,400	568	900
400x350	4022	400	350	470	470	800	800	1,082	2,350	70	1,600	590	900
400x350	4022D	400	350	510	510	900	880	1,232	2,400	70	1,700	547	1,000
400x350	6019	400	350	463	463	800	800	1,074	2,400	70	1,600	583	830
500x350	6022	500	350	598	598	950	950	1,174	2,500	85	1,800	713	1,050
500x400	4415	500	400	550	550	900	900	1,082	2,400	80	1,600	590	900
500x400	6028	500	400	550	550	1,100	1,100	1,324	2,400	80	1,800	690	1,300
500x400	6029	500	400	584	584	1,000	1,000	1,332	2,800	90	1,800	739	1,100
500x400	6029D	500	400	700	700	1,100	1,100	1,426	2,800	110	2,050	855	1,116
600x450	6575	600	450	650	650	1,200	1,200	1,382	2,600	-	-	680	1,100
600x400	6810	600	400	650	650	1,400	1,400	1,588	2,600	-	-	700	1,150
700x600	8725	700	600	675	675	1,500	1,500	1,738	2,900	-	-	700	1,250
700x500	8020	700	500	675	675	1,700	1,700	1,994	2,900	-	-	700	1,350

Model VPCH

Dimensions: mm

PUMP SIZE	SN	DN	A	B	C	D	E	F	K	M	N	O	
50x40	207H	50	40	198.5	198.5	400	400	406.4	1,450	50	800	198.5	480
80x50	208H	80	50	253.5	253.5	450	450	482	1,550	60	900	253.5	480
100x80	209H	100	80	298.5	298.5	450	450	482	1,700	60	900	293.5	480
150x100	210H	150	100	306.5	306.5	540	540	588	1,850	60	1,000	344.5	530
200x150	212HS	200	150	353.5	353.5	600	600	694	1,900	70	1,200	373.5	600
200x150	213HS	200	150	358.5	358.5	600	600	744	1,900	75	1,300	378.5	600
250x200	330H	250	200	370.5	370.5	570	630	794	2,000	75	1,300	390.5	600
300x250	380H	300	250	395.5	395.5	620	680	894	2,100	75	1,500	415.5	650

Notes: Dimensions are in mm and for guidance only.  
 Certified drawings will be provided in all cases of actual construction.



# EBARA CORPORATION

**Head Office:**

11-1, Haneda Asahi-cho, Ohta-ku,

Tokyo, 144-8510 Japan

Phone: (81) 3-3743-6111

Fax : (81) 3-5736-3100

<http://www.ebara.co.jp>